

# STONE

IP54

Code ACJ9078

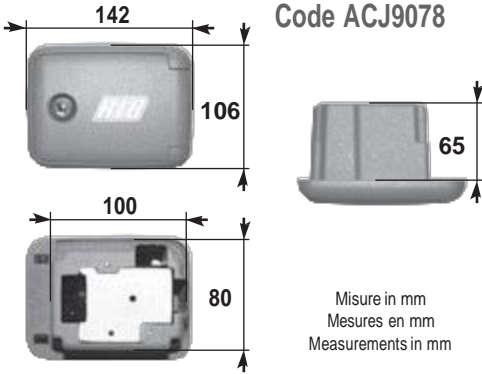

Misure in mm  
Mesures en mm  
Measurements in mm

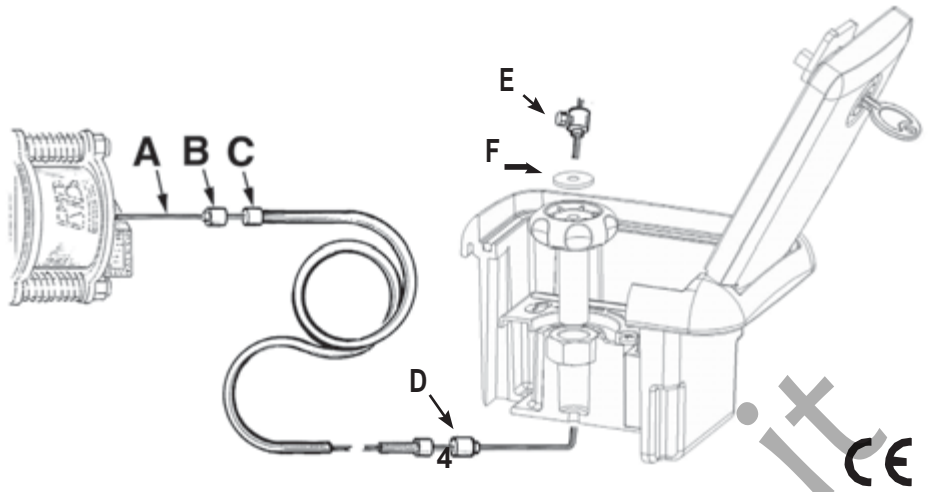

I

**ATTENZIONE:** impedire che le parti in plastica vengano a contatto con olio o grasso!

## PROCEDURA D'ASSEMBLAGGIO DELLA CASSAFORTE STONE

- Infilate la bussola di guida (B) del cavetto d'acciaio (A) lungo lo stesso, come raffigurato.
- Infilate la guaina di protezione (C) del cavetto d'acciaio lungo lo stesso.
- Infilate la bussola (D) di guida del cavetto d'acciaio lungo lo stesso, come raffigurato.
- Infilate la bussola con vite di fermo (E) in battuta contro la rondella (F) ed in seguito stringete la sua vite esagonale con una chiave n° 7.

F

**ATTENTION:** ne pas mettre les pieces en plastique en contact avec de l'huile ou de la graisse!

## PROCEDURE D'ASSEMBLAGE DU COFFRET-FORT STONE

- Enfiler l'arrêt de gaine (B) le long du câble acier (A) comme sur schéma.
- Enfiler la gaine de protection (C) le long du câble acier (A).
- Enfiler l'arrêt de gaine (D) le long du câble acier (A) comme sur schéma.
- Enfiler l'arrêt de câble (E) contre la partie (F) et serrer la vis avec une clé n° 7.

BG

**IMPORTANT:** Please make sure that all plastic parts does not come in contact with grease or oil!

## STONE STRONG BOX ASSEMBLY PROCEDURE

- Insert the steering compass (B) into the cable (A), as shown in the drawing.
- Insert the sheathed cable (C) along the cable.
- Insert the compass (D) onto the cable as shown.
- Insert the compass with the blocking screw (E) against part (F) and tighten the hexagonal screw with a key n° 7.

# STONE

IP54

Code ACJ9078

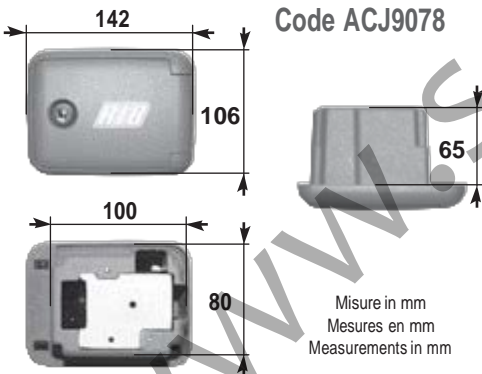

Misure in mm  
Mesures en mm  
Measurements in mm

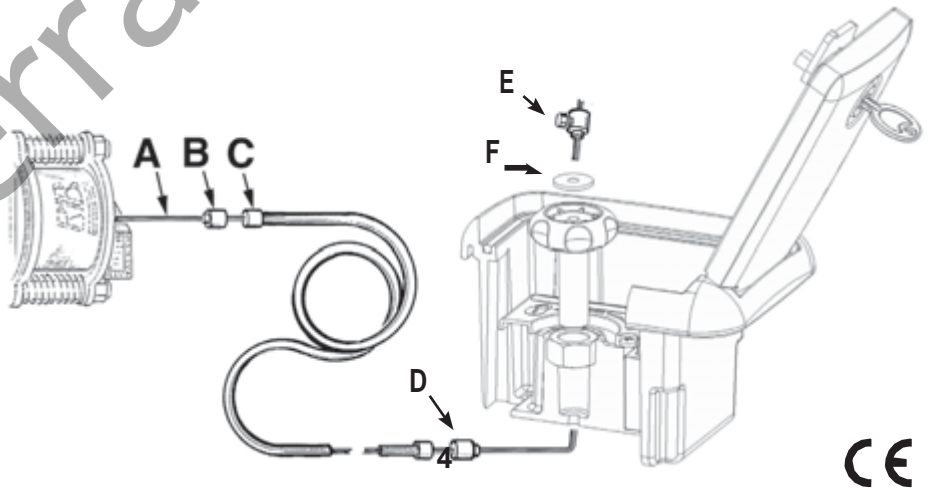

I

**ATTENZIONE:** impedire che le parti in plastica vengano a contatto con olio o grasso!

## PROCEDURA D'ASSEMBLAGGIO DELLA CASSAFORTE STONE

- Infilate la bussola di guida (B) del cavetto d'acciaio (A) lungo lo stesso, come raffigurato.
- Infilate la guaina di protezione (C) del cavetto d'acciaio lungo lo stesso.
- Infilate la bussola (D) di guida del cavetto d'acciaio lungo lo stesso, come raffigurato.
- Infilate la bussola con vite di fermo (E) in battuta contro la rondella (F) ed in seguito stringete la sua vite esagonale con una chiave n° 7.

F

**ATTENTION:** ne pas mettre les pieces en plastique en contact avec de l'huile ou de la graisse!

## PROCEDURE D'ASSEMBLAGE DU COFFRET-FORT STONE

- Enfiler l'arrêt de gaine (B) le long du câble acier (A) comme sur schéma.
- Enfiler la gaine de protection (C) le long du câble acier (A).
- Enfiler l'arrêt de gaine (D) le long du câble acier (A) comme sur schéma.
- Enfiler l'arrêt de câble (E) contre la partie (F) et serrer la vis avec une clé n° 7.

BG

**IMPORTANT:** Please make sure that all plastic parts does not come in contact with grease or oil!

## STONE STRONG BOX ASSEMBLY PROCEDURE

- Insert the steering compass (B) into the cable (A), as shown in the drawing.
- Insert the sheathed cable (C) along the cable.
- Insert the compass (D) onto the cable as shown.
- Insert the compass with the blocking screw (E) against part (F) and tighten the hexagonal screw with a key n° 7.

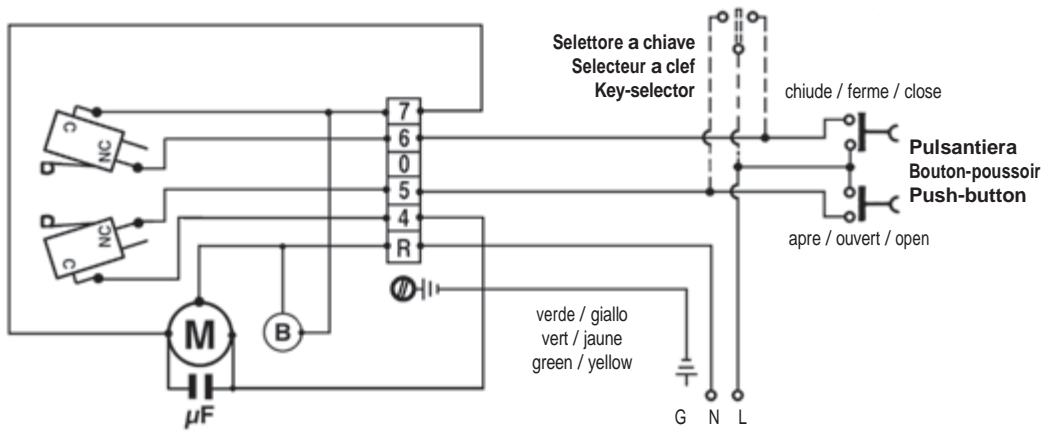

- B = Elettrofreno - Electrofrein - Electrobrake
- G = Terra - Terre - Earth
- LN = Linea Monofase - Ligne Monophasé  
Line 1-Phase
- M = Motore - Moteur - Motor
- U = Comune - Commun - Common
- V/W = Invertitori - Convertisseurs - Inverters



automatismi per cancelli  
automatic entry systems

**COMPANY WITH  
QUALITY SYSTEM  
CERTIFIED BY DNV**

= ISO 9001 =

25014 CASTENEDOLO (BS) - ITALY

Via Matteotti, 162

Tel. +39.030.2135811

Fax +39.030.21358279

www.ribind.it - ribind@ribind.it



Cod. CVA1464 - 26052014 - Rev. 09

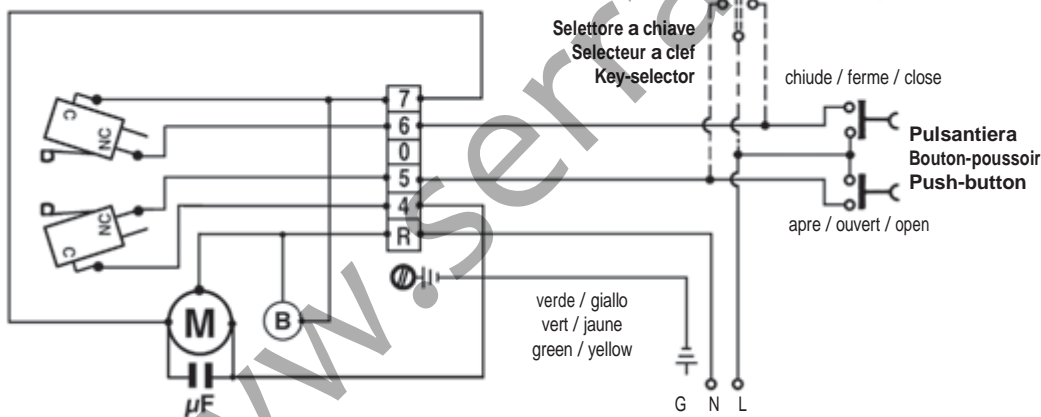
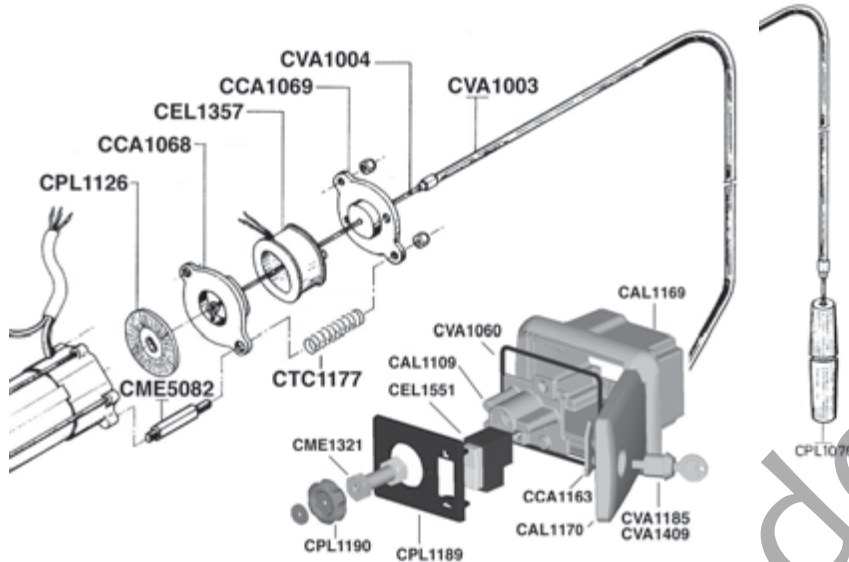

- B = Elettrofreno - Electrofrein - Electrobrake
- G = Terra - Terre - Earth
- LN = Linea Monofase - Ligne Monophasé  
Line 1-Phase
- M = Motore - Moteur - Motor
- U = Comune - Commun - Common
- V/W = Invertitori - Convertisseurs - Inverters



automatismi per cancelli  
automatic entry systems

**COMPANY WITH  
QUALITY SYSTEM  
CERTIFIED BY DNV**

= ISO 9001 =

25014 CASTENEDOLO (BS) - ITALY

Via Matteotti, 162

Tel. +39.030.2135811

Fax +39.030.21358279

www.ribind.it - ribind@ribind.it



Cod. CVA1464 - 26052014 - Rev. 09

